

SATAKE CORPORATION



Satake has a global role in the creation of high quality foods

SATAKE CORPORATION

New Methods of Corn Degermination

A Presentation of The Satake Group

October 08, 2000

SATAKE CORPORATION

New Methods of Corn Degermination

- How did Satake become interested in corn degermination?
 - Satake has always been involved in removing bran and germ from rice.
 - During the past few years, Satake has gained experience and knowledge in removing bran and germ from wheat.
 - Satake is looking for ways to apply this knowledge and experience to the processing of other grains.

New Methods of Corn Degermination

- What are Satake's goals in developing a new technology?
 - Increased yield
 - Improved product quality
 - A shorter or less costly process
 - Ability to market these improvements profitably

The Satake VBF10A Degermer



SATAKE CORPORATION

The Satake VBF10A Degermer

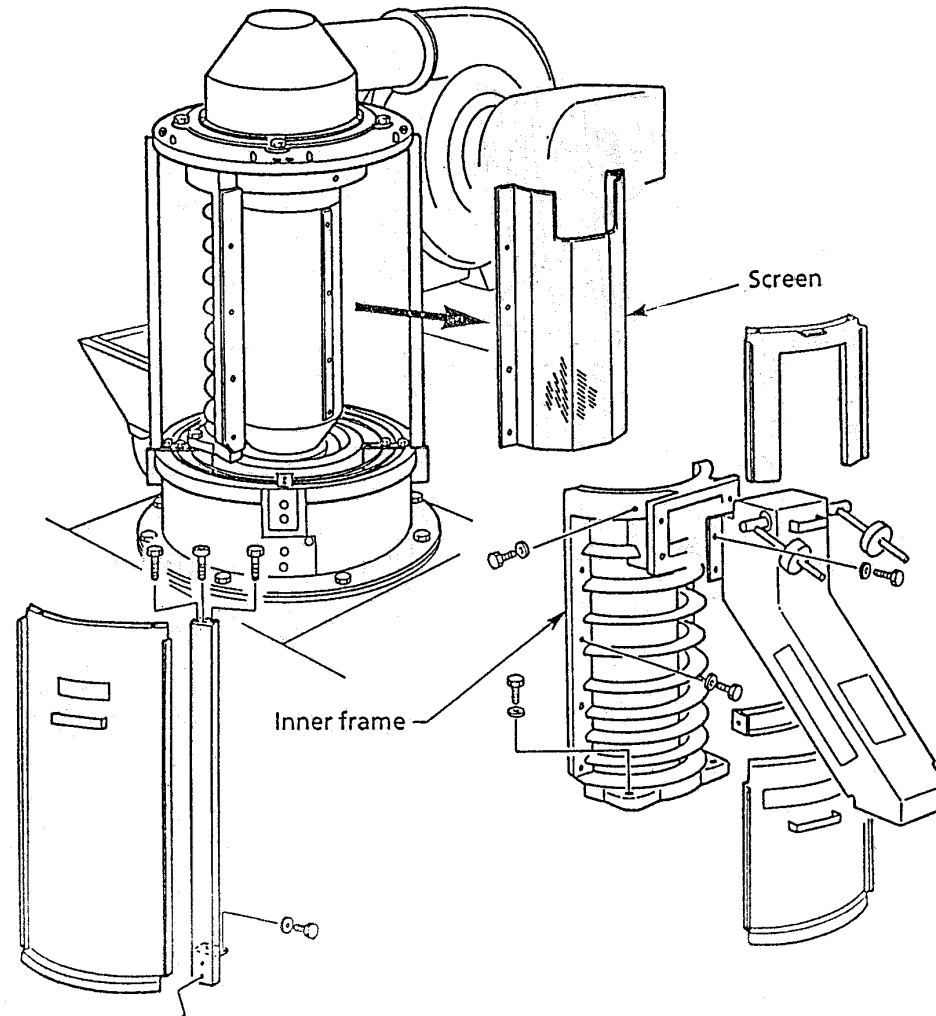

The Satake VBF10A Corn Degermer

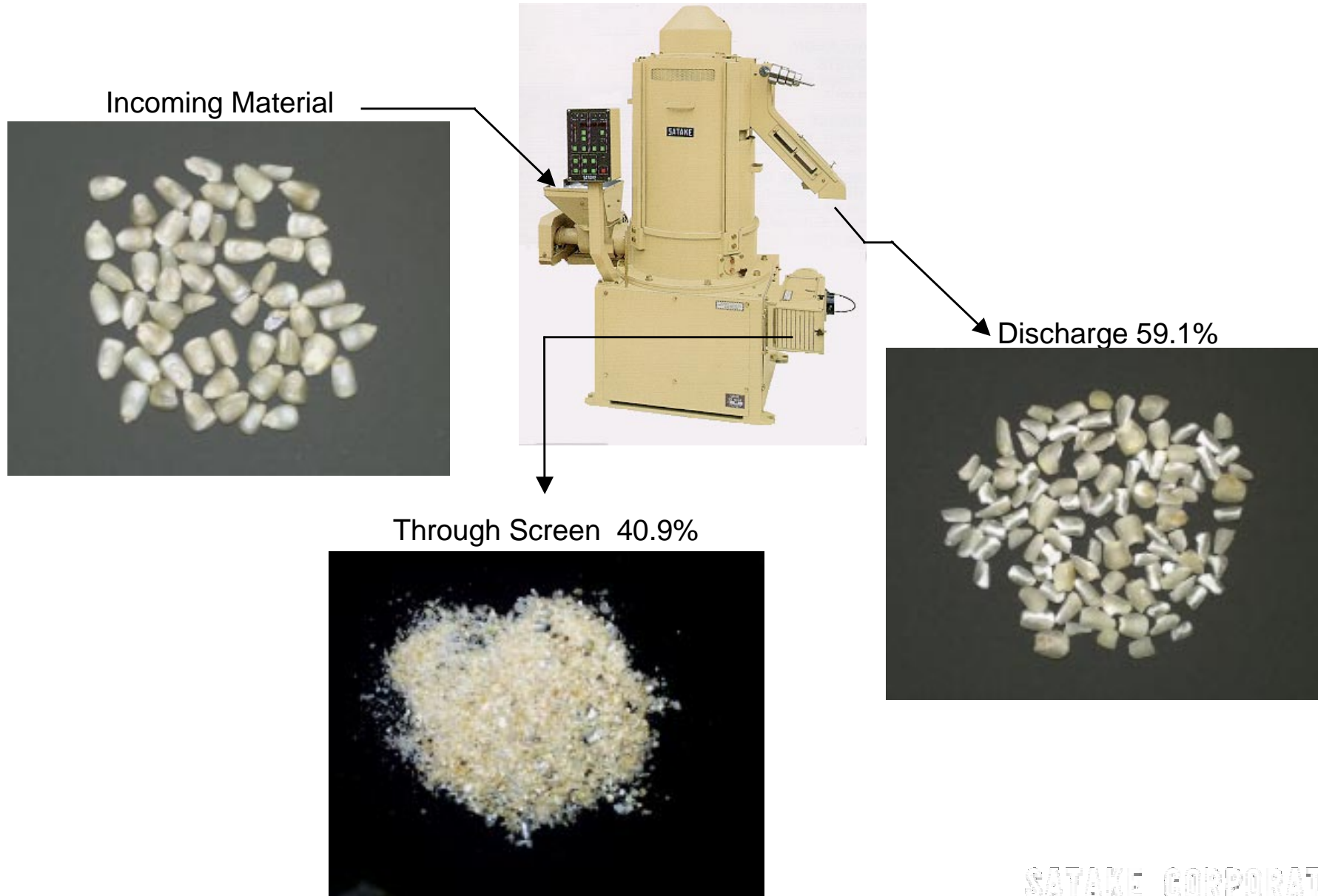

Flow Sheet of Corn Degermination

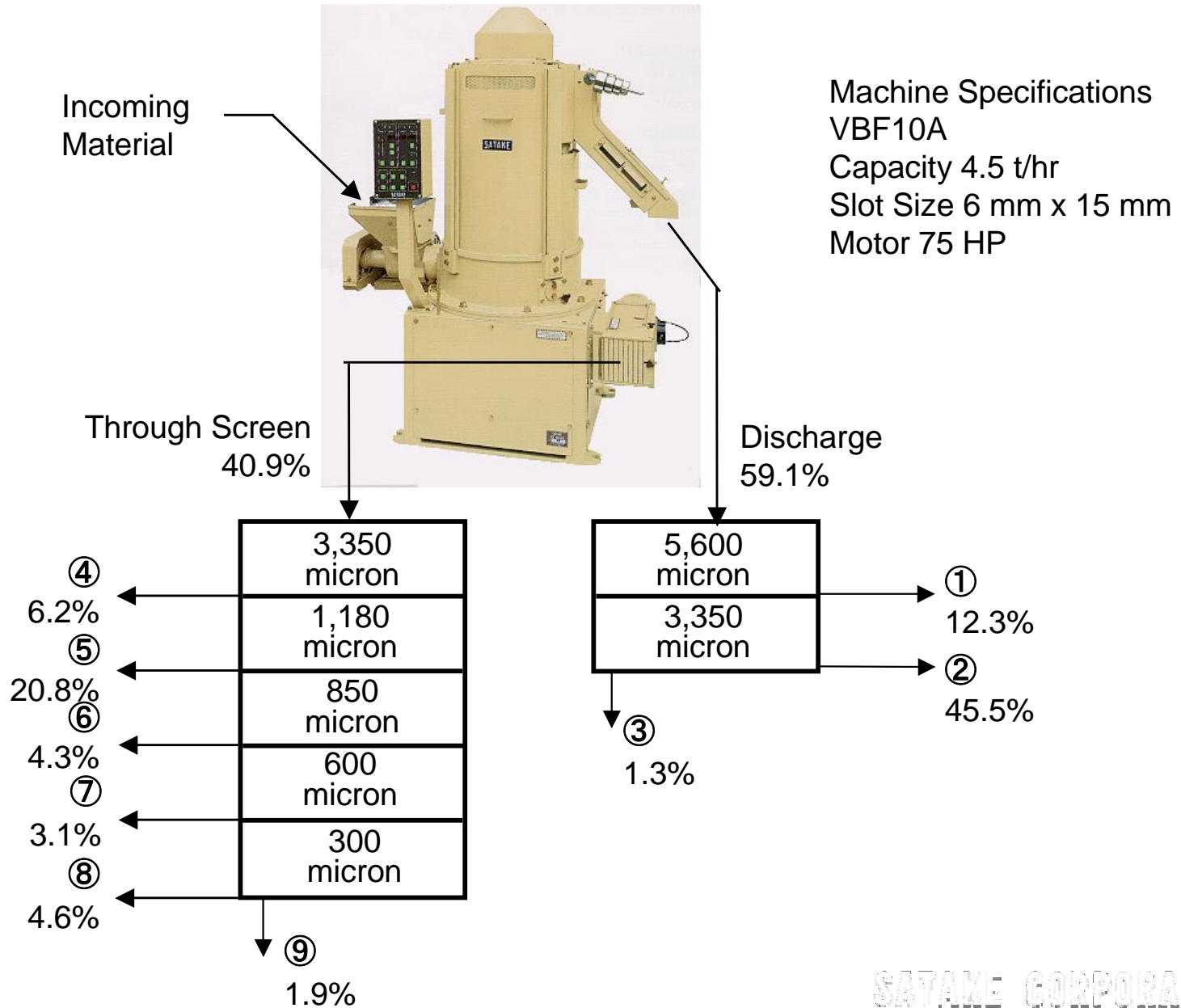

Discharge of VBF10A Degermer



Flow Sheet of Corn Degermination

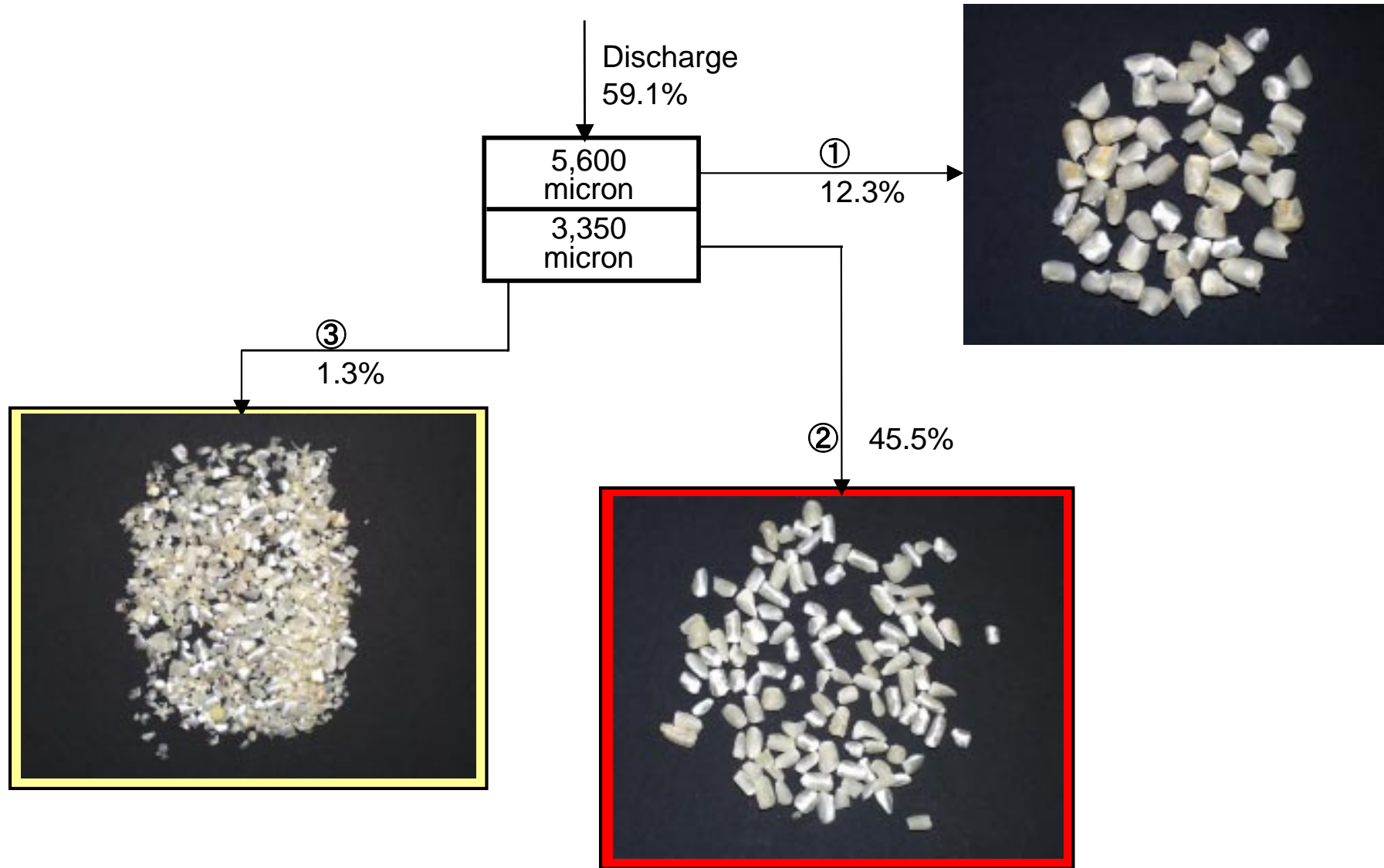

Discharge of VBF10A Over 3350 Micron (45%)



Discharge of VBF10A Through 3350 Micron (1.3%)



Product Exiting Through Screens



SAYAKE CORPORATION

Products Exiting Through Screens

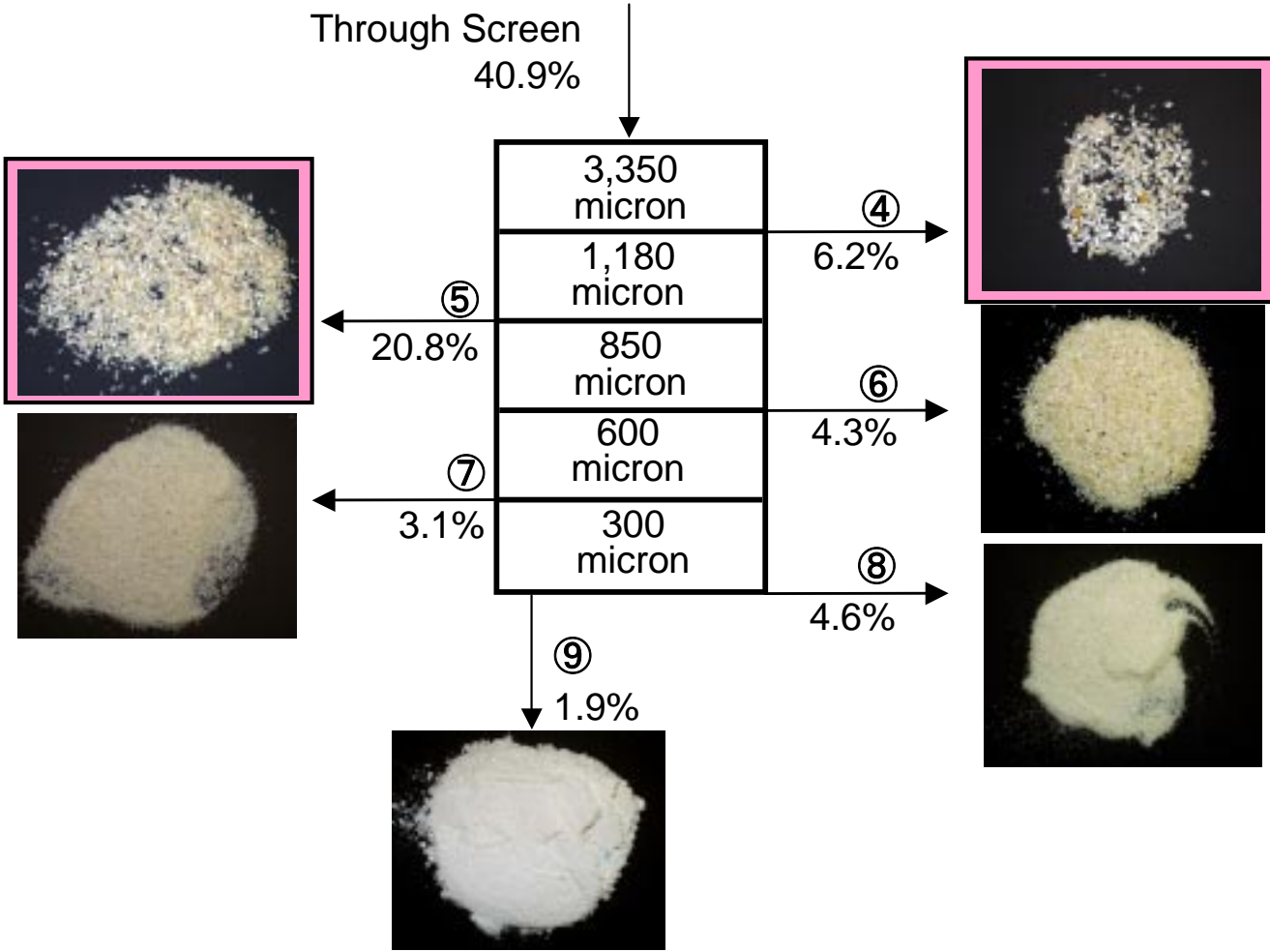

Through Screens of VBF10A Over 3350 Micron (6.2%)



Through Screens of VBF10A Over 1180 Micron (20.8%)



Through Screens of VBF10A Over 600 Micron (7.4%)



Fine Grits and Flour Through Screens of VBF10A (6.5%)



Process Samples of Satake Maize Degermer



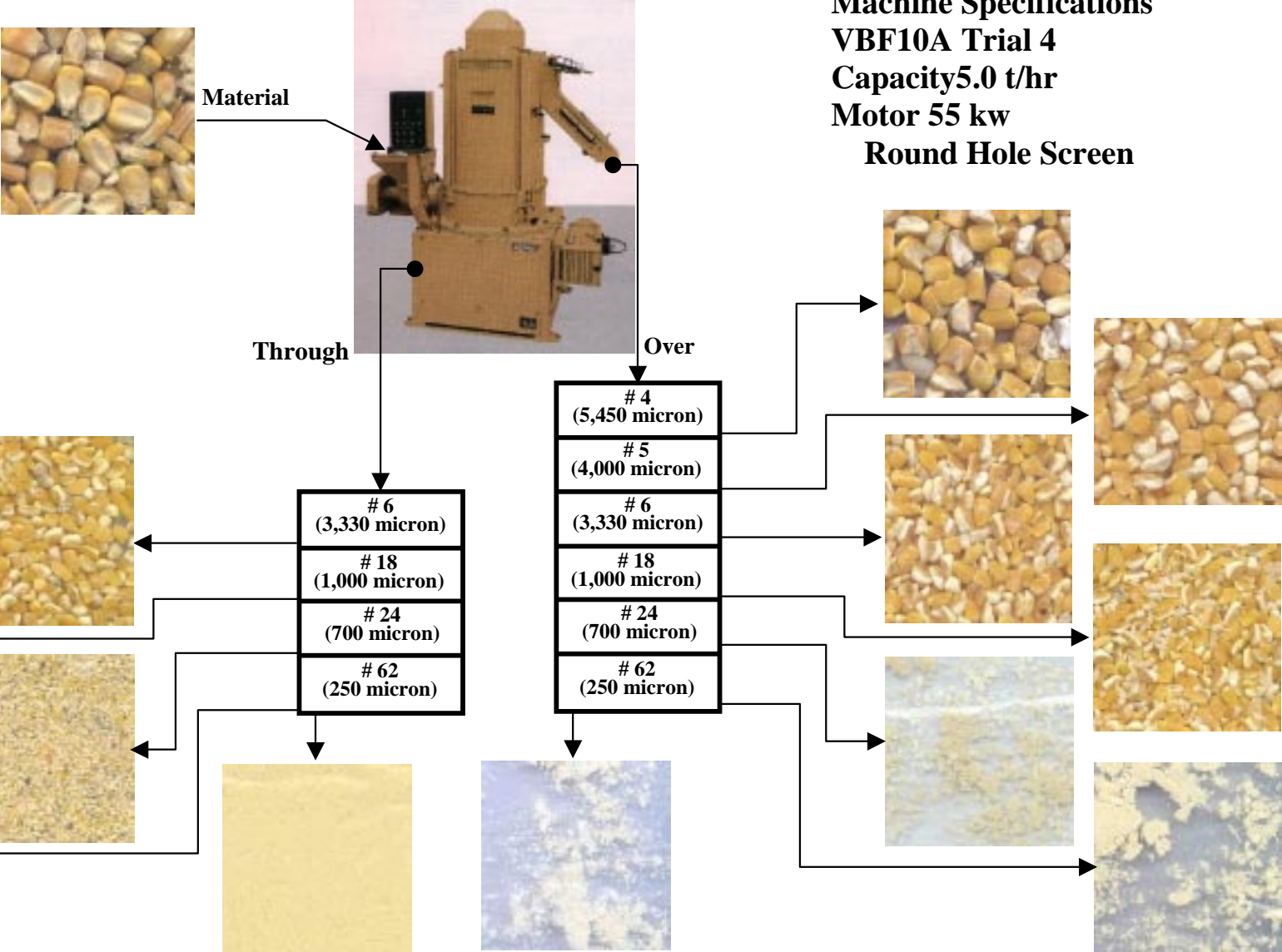



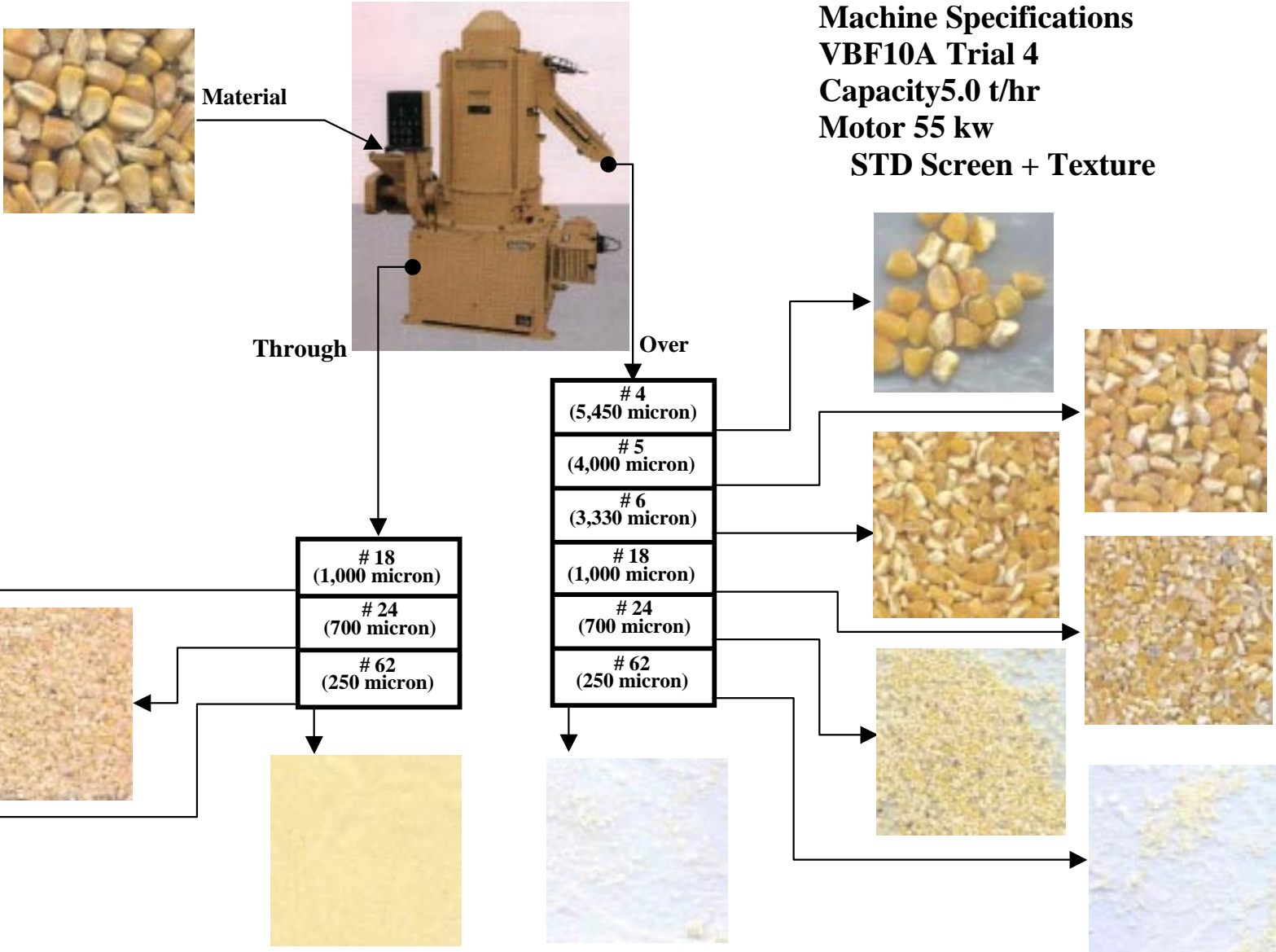























Machine Specifications
VBF10A Trial 4
Capacity 5.0 t/hr
Motor 55 kw
Round Hole Screen





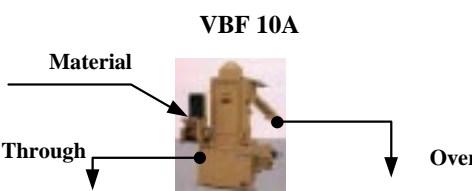



Process Samples of Satake Maize Degermer



Sifted Samples from Degermer

Material	Process	# 4 Over (5,450 micron)	# 5 Over (4,000 micron)	# 6 Over (3,330 micron)	# 18 Over (1,000 micron)	# 24 Over (700 micron)	# 62 Over (250 micron)	# 62 Through (250 micron)	
	EXISTNG								
	VBF10A (Trial 4) Round Hole Screen (4mm)	Over							
		Through							
VBF10A (Trial 5) STD Screen + Texture	Over								
	Through	 <p style="text-align: center;">VBF 10A</p>							

Sample Comparison

	# 5 Over (4,000 micron)	# 6 Over (3,330 micron)	# 18 Over (1,000 micron)
EXISTING Decorticator			
SATAKE Maize Degermer VBF 10A			

Flow Sheet for Corn Degermination Process

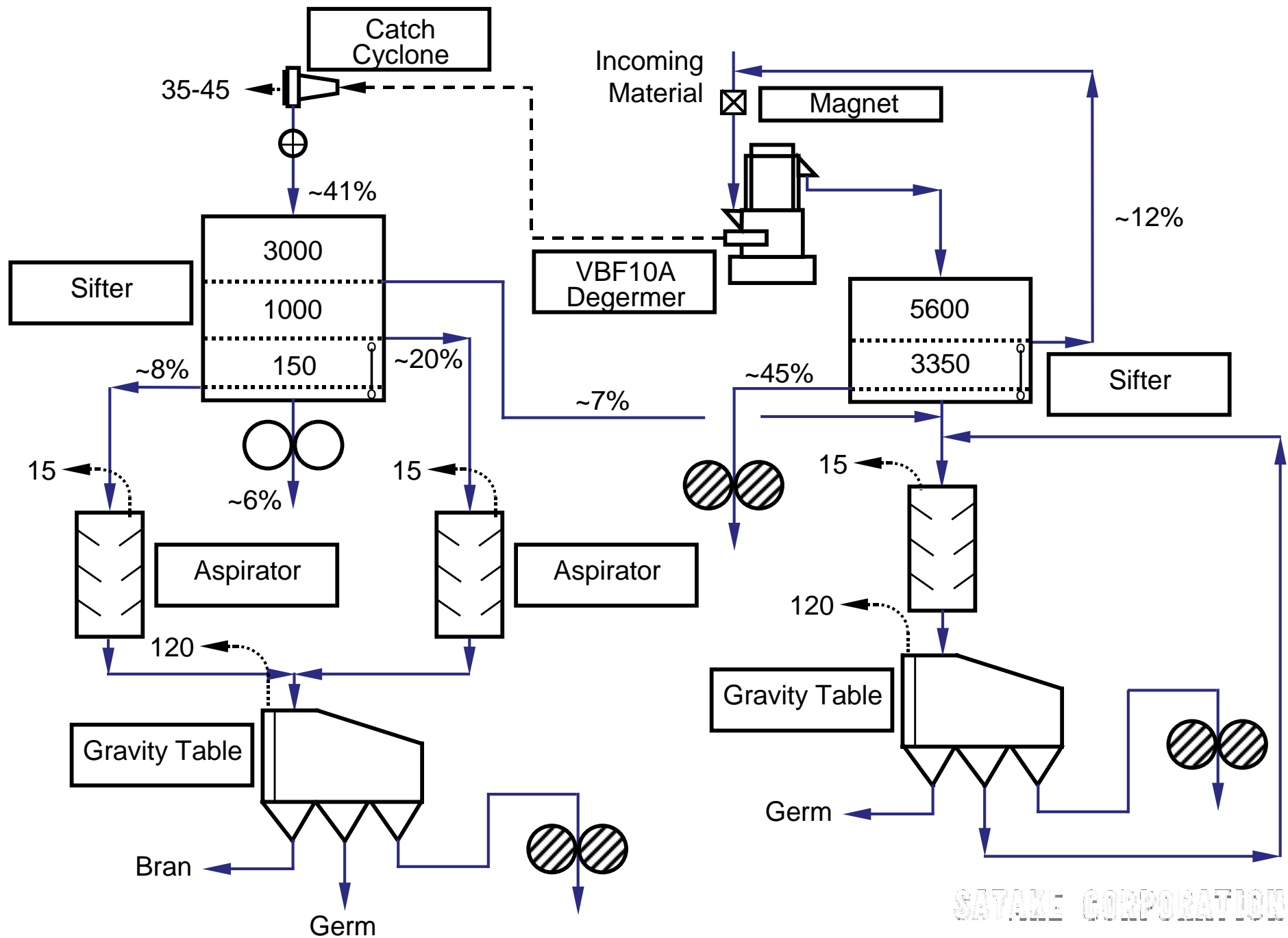

New Methods of Corn Degermination

- What are the benefits of this new system?
 - The production of larger quantities of pure endosperm shifts the mechanical requirements from purification to reduction.
 - Since reduction is typically more efficient than purification, increases in yield can be expected.
 - The process can be shortened, particularly in the area of purification.
 - Greater profitability can be offered to the miller.