

# ABRASION DEBRANNER VTA10



## Application

The Satake Debranning Machine Type VTA is a high capacity machine designed for removing the outer bran layers from cereals such as wheat, barley and rye by abrasion. The machine is exceptionally hard wearing and is designed for trouble free 24 hour production.

## Operating Principle

The stock enters the VTA via a regulator valve and into the milling chamber. The product works its way between the vertical abrasive stones, resistance bars and screen. An exhaust connection on the machine pulls removed bran and dust through the screens and onwards to be collected in a cyclone or dust collector. The degree of milling is controlled by a weighted outlet gate and can be adjusted in seconds.

## Option

Milling degree can be PLC controlled by an 'Autoweight' system fitted to the outlet get.

## Combination

The machine can be used as 'stand alone'. For very high debranning rates, the VTA can be used before the VCW PeriTec unit or in series.

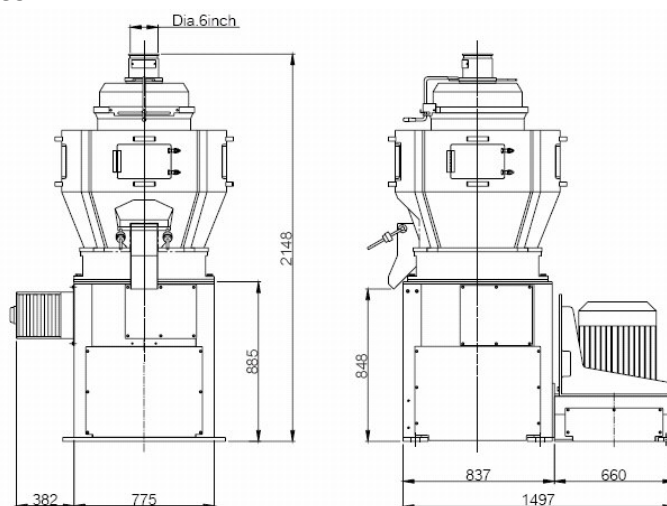
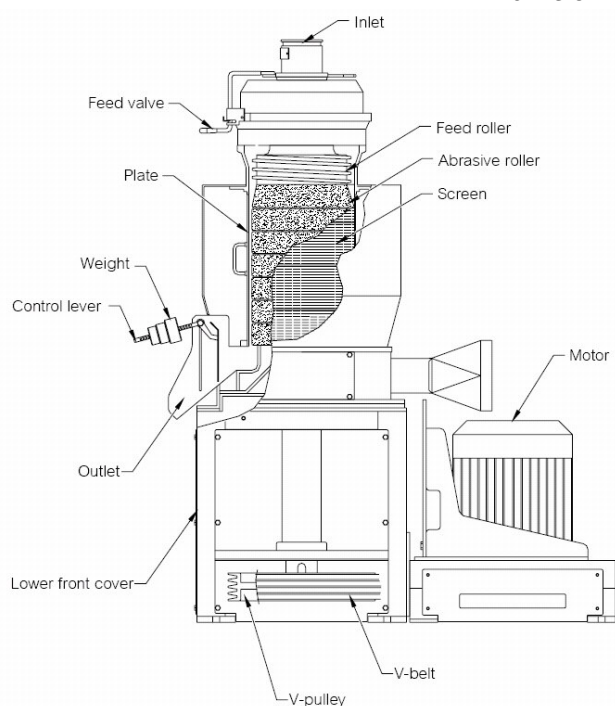

Motor: 30 – 55kW 6 Pole

Required Exhaust: 50m<sup>3</sup>/min at 1.0 ~ 1.5 kPa

Weight Without Motor: 1,300 kg approx.

All Satake products are the subject of continuous development and, as a result, their specification may change and differ in detail from that outlined in this leaflet.

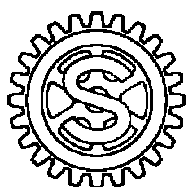

**SATAKE CORPORATION**  
**UK DIVISION**  
PO Box 53, Horsfield Way  
Bredbury, Stockport  
SK6 2FG, England

Telephone: +44 (0) 161 406 3800  
Facsimile: +44 (0) 161 406 3801  
E-mail: sales@satake.co.uk  
Website: www.satake.co.uk