

TWIN BULK WEIGHER STBS



The Satake STBS Weigher is reliable compact machine of sanitary construction.

Features:

- Extremely accurate weighing for process control and monitoring
- Compact design requires less headroom for easier installation
- Can be used to control the flow rate of product
- Can be linked to central PLC for remote operation and monitoring

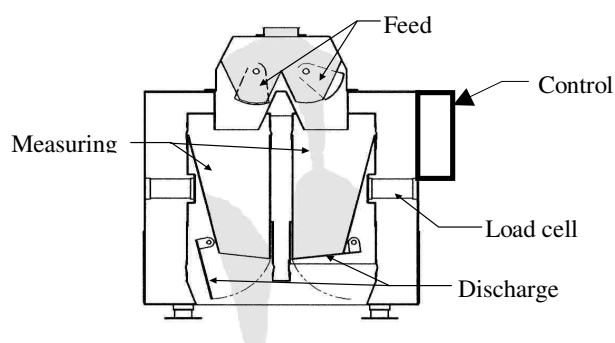

Model	STBS40	STBS80	STBS120	STBS200
Capacity	20 m ³ /h	40 m ³ /h	60 m ³ /h	100 m ³ /h
Accuracy	±0.1 %FS	±0.1 %FS	±0.1 %FS	±0.1 %FS
Rated Voltage	AC100V±15V (50/60 Hz)	AC100V±15V (50/60 Hz)	AC100V±15V (50/60 Hz)	AC100V±15V (50/60 Hz)
Power Consumption	100 W	100 W	100 W	100 W
Air Pressure	0.4 MPa	0.4 MPa	0.4 MPa	0.4 MPa
Air Volume	25 L/min(nor)	40 L/min(nor)	65 L/min(nor)	65 L/min(nor)
Ambient Temp.	0 ~ 50°C	0 ~ 50°C	0 ~ 50°C	0 ~ 50°C

Method of Operation:

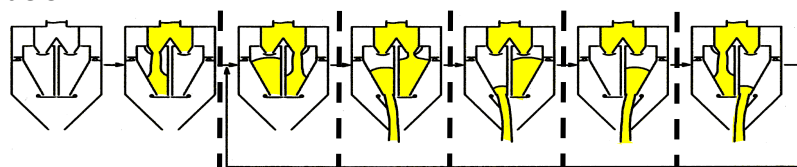

Machine	A	B	C	D
STBS 40	1278	1070	720	∅ 152
STBS 80	1520	1434	1180	∅ 235.3
STBS 120	1520	1434	1180	∅ 235.3
STBS 200	1840	2040	1420	∅ 269

All dimensions in mm

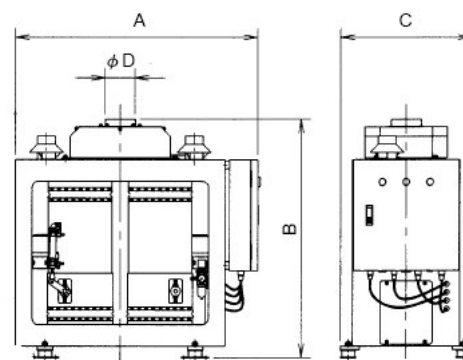

All Satake products are the subject of continuous development and, as a result, their specification may change and differ in detail from that outlined in this leaflet.

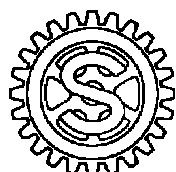

SATAKE CORPORATION
UK DIVISION
PO Box 53, Horsfield Way
Bredbury, Stockport
SK6 2FG, England

Telephone: +44 (0) 161 406 3800
Facsimile: +44 (0) 161 406 3801
E-mail: sales@satake.co.uk
Website: www.satake.co.uk