

New Paddy Husker

# PADDY HUSKER

HR10FT



HR10FT

SATAKE CORPORATION

Satake, as a total food engineering company, introduced its unique technologies into the New Paddy Husker HR10FT. It achieved performance and usability at the utmost level.

## FEATURES:

### 1. New Feeder

A vibratory feeder is introduced. Smooth, consistent and large throughput is achieved at the same time. The feeder volume is controlled to provide a linear non-stop flow rate.

### 2. New Chute

A new chute extends to the husking point and adjusted to the best position automatically. Paddy flowing uniformly on the chute is fed to the rubber rolls evenly and appropriately. It improved husking efficiency and recovery, compared with any other type of husker.

### 3. New Belt Drive

A double-toothed belt drive is used on the new husker. The new belt drive simplifies belt routing and extends belt life. It eliminates power loss due to slippage and thus improves husking efficiency.

### 4. New Aspirator

A wide body and adjustable distribution valve improve capacity and efficiency. The traditional immatures outlet is eliminated from this model because of its excellent separation of rice from husk. Only two outlets are enough to allow you to obtain efficient separation.

### 5. New Concept

Ease of operation and maintenance has been considered. A step and a rolls and tools retainer are newly introduced for the ease of roll replacement. The aspirator has inspection windows on four sides. There are removable inspection covers on both right and left side of the aspirator body, allowing easy maintenance.

## PADDY HUSKER

### Specifications

Model	HR10FT
Component (Husker & Aspirator)	HU10FT+HA10W
Input Capacity (t/h on Long Grain Rice)	6~8
Required Power(kw)	11.4

### Dimensions

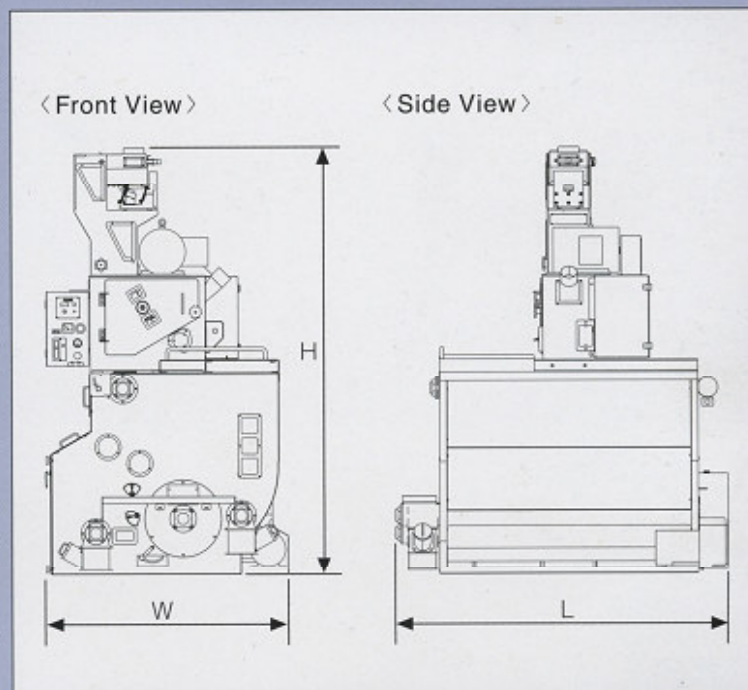

Model	W(mm)	L(mm)	H(mm)	Net Weight (kg)
HR10FT	1,550	2,040	2,650	1,190

All Satake products are the subject of continuous development and, as a result, their specification may change and differ in detail from those shown.

SATAKE CORPORATION is registered with ISO9001 standards for quality management systems and ISO14001 standards for environmental management systems.



ISO9001



ISO14001

## SATAKE CORPORATION

### Head Office

2-3D, Saijo-Nishihonmachi, Higashi-Hiroshima, 739-8602, Japan  
Tel : +81-82-420-8560/8539  
Fax : +81-82-420-0865  
e-mail: ig.hiroshima@satake-japan.co.jp  
URL : www.satake-japan.co.jp

### UK Division

P.O.Box 53, Bredbury, Stockport, Cheshire, SK6 2FG, England  
Tel : +44-161-406-3800  
Fax : +44-161-406-3801  
e-mail : sales@satake.co.uk  
URL : www.satake.co.uk

### New Delhi Office

11th Floor, Dr. Gopal Das Bhawan, 28 Barakhamba Road, New Delhi 110001 India  
Tel : +91-11-2373-8646  
Fax : +91-11-2373-8647

### Beijing Office

Room 203B, Chang Xin Building, No.39 An Ding Road,Chao Yang District, Beijing, P.R. China  
Tel : +86-10-6443-3822  
Fax : +86-10-6443-4188

### Bangkok Office

133 Moo 5, Bangkok Industrial Park Tivanon, Road, Patumthani 12000 Thailand  
Tel : +66-2-501-1223  
Fax : +66-2-501-1225  
e-mail : sataketh@asia.com

### Yangon Office

No.4 Kanthaya Street, South Okkalapa Township, Yangon Myanmar  
Tel : +95-1-578303  
Fax : +95-1-570610

### SATAKE USA INC.

10905 Cash Road, Stafford, Texas 77477 U.S.A.  
Tel : +1-281-276-3600  
Fax : +1-281-494-1375  
e-mail : rice@satake-usa.com  
URL : www.satake-usa.com

### SATAKE AUSTRALIA PTY. LTD.

23-25 Marigold Street, Reevesby, NSW 2212 Australia  
Tel : +61-2-9774-1155  
Fax : +61-2-9774-1248  
e-mail : sataus@ozemail.com.au  
URL : www.satake.com.au

### SATAKE (THAILAND) CO., LTD.

133 Moo 5, Bangkok Industrial Park Tivanon Road, Patumthani 12000 Thailand  
Tel : +66-2-501-1180  
Fax : +66-2-501-1188  
e-mail : sataketh@asia.com

### SATAKE MANUFACTURING (SUZHOU) CO., LTD.

Jin Feng Road, Suzhou New District, Suzhou City, Jiangsu Province P.R.China  
Tel : +86-512-6536-8225  
Fax : +86-512-6536-3004  
URL : www.satake-suzhou.com.cn

### SATAKE (CANADA) INC.

2550 Argenta Road, Suite 119 Mississauga, Ontario L5N 5R1 Canada  
Tel : +1-905-858-0791  
Fax : +1-905-858-0957

### SATAKE AMERICA LATINA LTDA.

Conjunto Empresarial Joinville Rua Xavantes, 155-Bairro Afradores 89203-210-Joinville-Santa Catarina, Brazil  
Tel : +55-47-438-0413  
Fax : +55-47-438-7932  
e-mail : ricardo@satake.com.br