

SATAKE

IN-LINE FLAKE DISRUPTER SEDB



The Satake In-Line Flake Disrupter SEDB has been developed to provide a more compact plant layout, by performing the flake disrupter process on stock whilst it is being pneumatically conveyed.

The material moving through the pins is violently agitated by the speed vortices and the flakes are reduced to fragments before passing through the outlet. Any bran particles present are not broken down and therefore the action of the disrupter does not harm the ash or colour.

Installation

Machines are dynamically balanced to fine limits during manufacturing as matched units. No other site balancing is required. The machine axis must be truly horizontal or vertical when the machine is installed. Legs or stands are supplied to suit the required installation.

Type	Capacity (t/h)	Motor (kW)	Weight (kg)	Dimensions (mm)		
				A (Diam)	B	C
SEDB037A	3.6	3.7	92	543	542	774
SEDB055A	5.4	5.5				
SEDB075A	6.8	7.5				
SEDB110A	9.0	11.0				

Weight excludes motor
Dimension B excludes outlet

Dimension C includes standard legs but excludes inlet
SEDB150A(15kW) and SEDB185A(18.5kW) units are also available

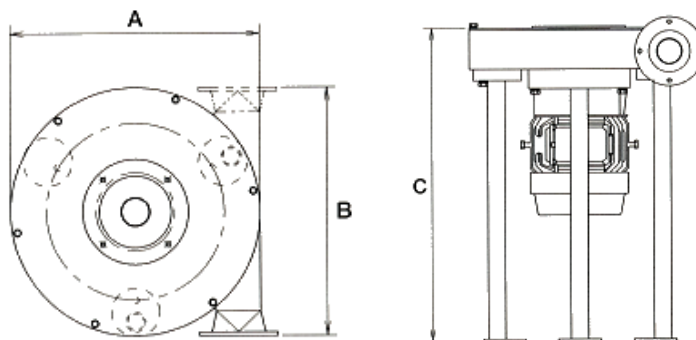

All Satake products are the subject of continuous development and, as a result, their specification may change and differ in detail from that outlined in this leaflet.

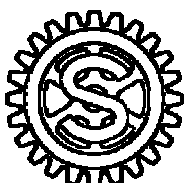

SATAKE

Building on a Tradition of Excellence

Hiroshima, Japan
Houston, U.S.A.
Stockport, England

Tel: +81 824 20 8560 Fax: +81 824 20 0865
Tel: +1 713 772 8400 Fax: +1 713 772 8484
Tel: +44 161 406 3800 Fax: +44 161 406 3801

www.satake-japan.co.jp JDG02056@nifty.ne.jp
www.satake-usa.com cereal@satake-usa.com
www.satake.co.uk sales@satake.co.uk